

SV

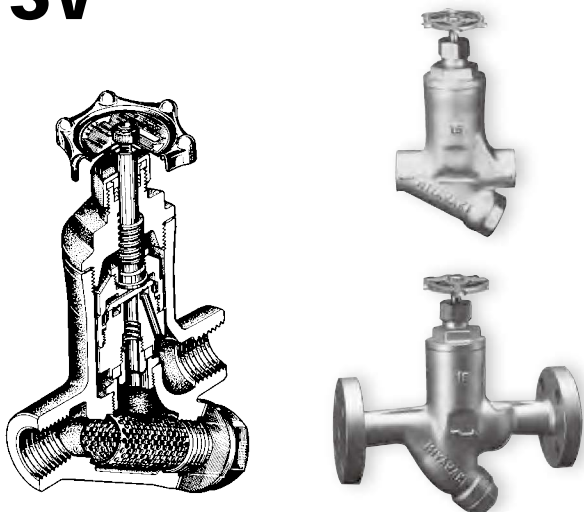

SL3

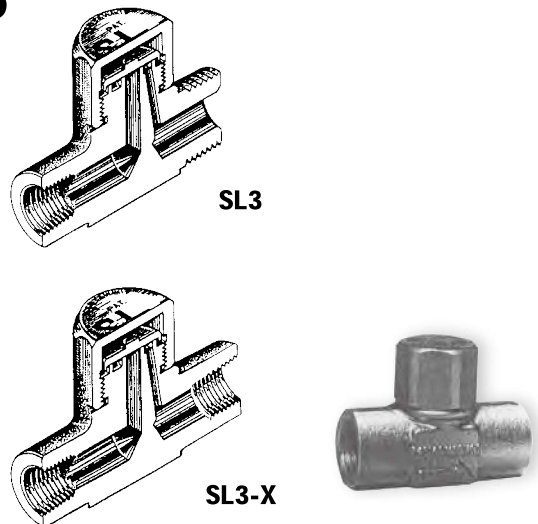

Capacity Chart SV-N

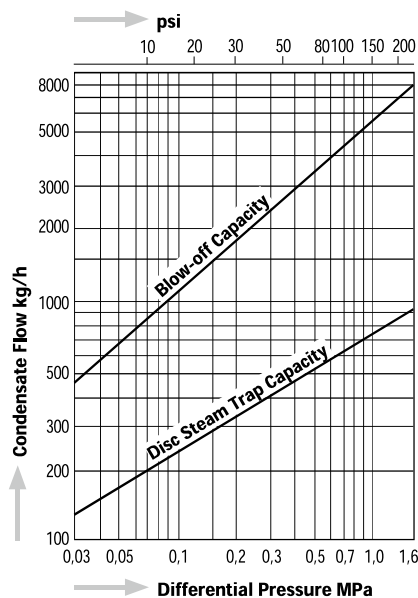

Capacity Chart SV1

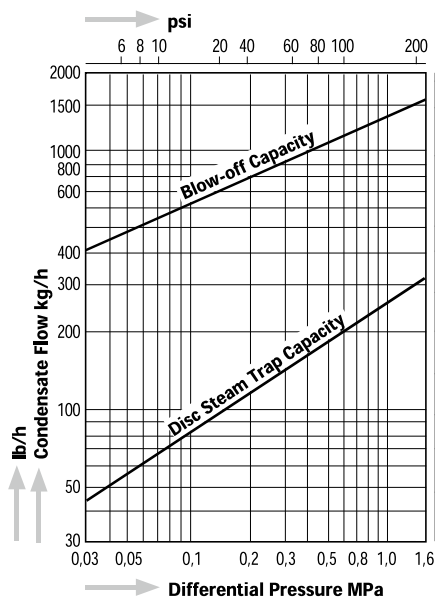

Capacity Chart SL3

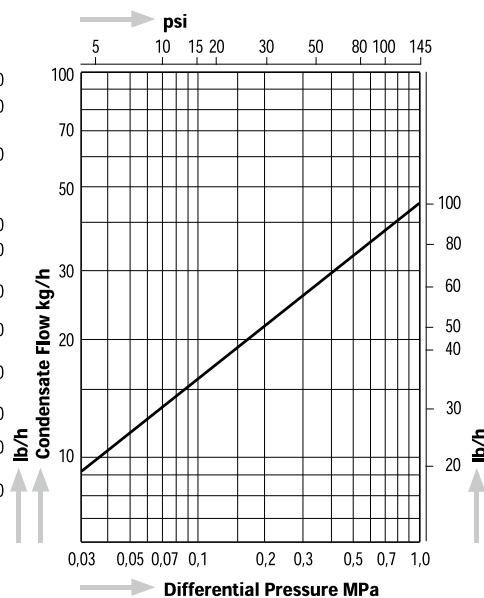

Dimensions

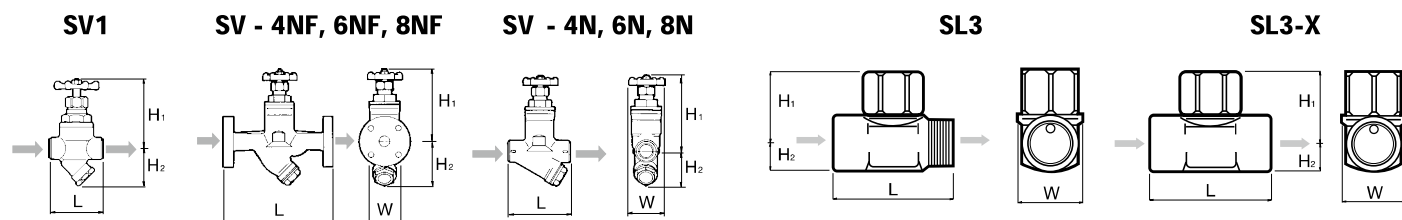

Model	Connections	Size	Max. Operating Pressure		Max. Operating Temperature		Dimensions (mm)				Dimensions (in)				Body Material	Weight									
			MPa	psig	°C	°F	L	H1	H2	W	L	H1	H2	W		kg	lb								
SV1	Screwed Rc, NPT	3/8", 1/2"	1.6	230	220	428	75	105	53	65	3.0	4.1	2.1	2.6	Cast Steel WCB	1.0	2.2								
		3/4", 1"						107				4.2				1.2	2.6								
SV -	Screwed Rc, NPT	1/2"					1.6	230	220	428	110	60	65	65		4.3	2.4	2.6	2.6	Cast Iron FC250	2.4	5.3			
		3/4"										155					65				65	6.1	2.6	2.6	2.5
		1"									220	90	65	4.7		2.8	2.7	5.9	3.5		2.6	2.7	5.9		
		1/2"																				220	8.7	4.1	9.0
		3/4"																				230	9.1	4.7	10.3
		1"																				230	9.1	5.2	11.5
SL3	Screwed Inlet : Rc, NPT Outlet: G	1/4"					1.0	145	400	752	40	22	8	19		1.6	0.9	0.3	0.7	Stainless Steel SUS416	0.06	0.13			
SL3-X	Screwed Rc, NPT	1/4"					1.0	145	400	752	40	22	8	19		1.6	0.9	0.3	0.7		0.06	0.13			